



Gdansk
University of Technology



FOUNDATION
for CIVIL ENGINEERING DEVELOPMENT

THE EFFICIENCY OF SELECTED TRAFFIC CALMING DEVICES

International
Seminar

GAMBIT
2008

T. Szczuraszek J. Kempa
UNIVERSITY of TECHNOLOGY AND LIFE
SCIENCES in BYDGOSZCZ



Gdansk
University of Technology



FOUNDATION
for CIVIL ENGINEERING DEVELOPMENT

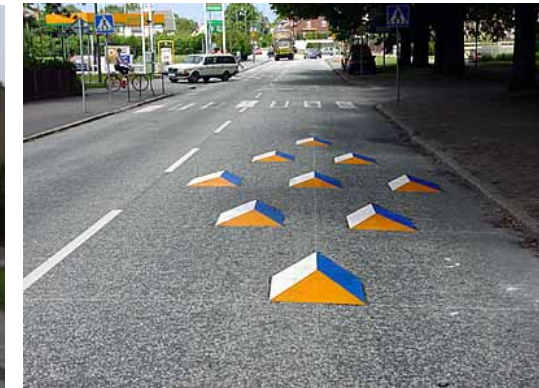

International
Seminar

**GAMBIT
2008**

T. Szczuraszek J. Kempa
UNIVERSITY of TECHNOLOGY AND LIFE
SCIENCES in BYDGOSZCZ



Gdansk
University of Technology



FOUNDATION
for CIVIL ENGINEERING DEVELOPMENT

The characteristic of trial sections:

- ✓ streets class: L and D
- ✓ series of humps – min. 4 units
- ✓ permissible speed – 30 km/h
- ✓ linear humps – U-16a and U-16c

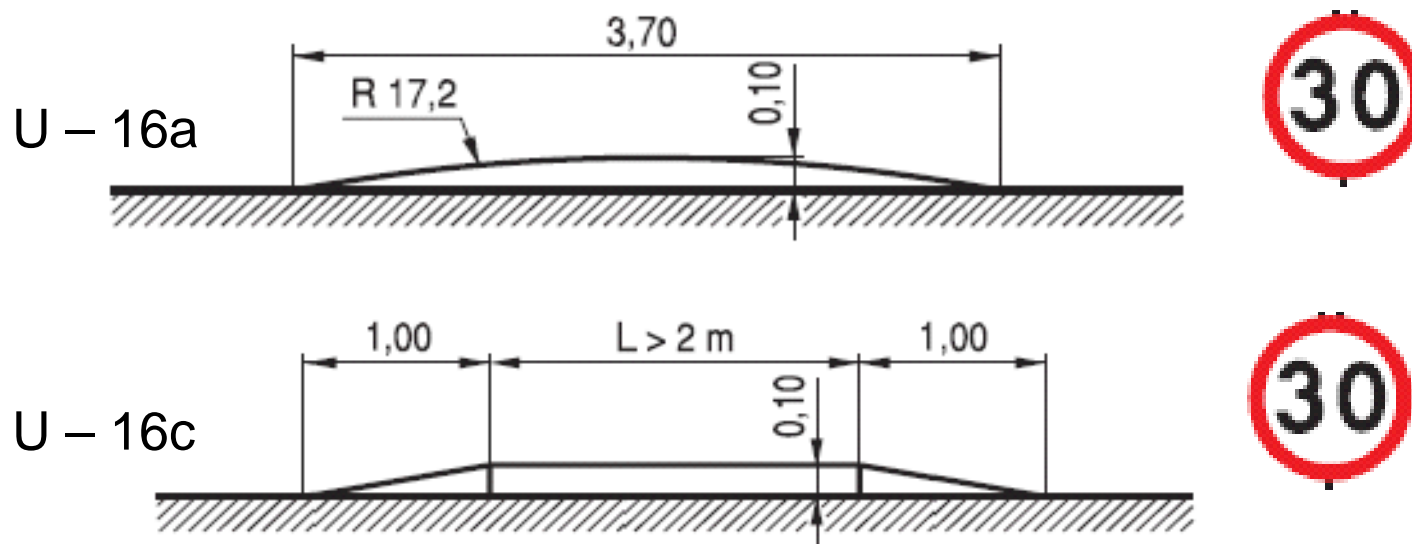

The limited speed humps (25 - 30 km/h)

T. Szczuraszek J. Kempa
UNIVERSITY of TECHNOLOGY AND LIFE
SCIENCES in BYDGOSZCZ

International
Seminar

GAMBIT
2008



Gdansk
University of Technology



FOUNDATION
for CIVIL ENGINEERING DEVELOPMENT

Depending on needs the humps can be applied as a singly one or as the series however one contains at least 3 humps. In case of the hump series, every next hump should be placed at the distance not smaller than 20 m and not longer than 150 m from the preceding one. Distances among the particular humps in series should be assigned on the strength of the local conditions, traffic volume, vehicles speed, etc.

International
Seminar

**GAMBIT
2008**

T. Szczuraszek J. Kempa
UNIVERSITY of TECHNOLOGY AND LIFE
SCIENCES in BYDGOSZCZ



Gdansk
University of Technology



FOUNDATION
for CIVIL ENGINEERING DEVELOPMENT



Picture of the 'Atrack' device

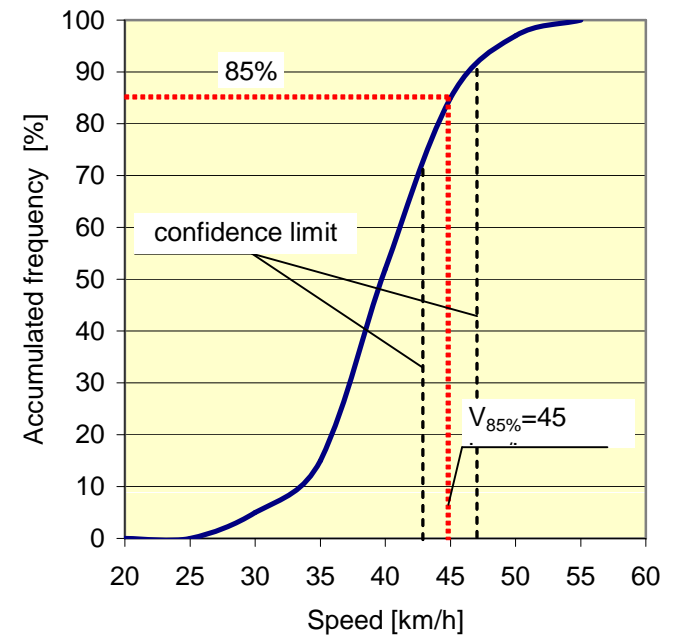

T. Szczuraszek J. Kempa
UNIVERSITY of TECHNOLOGY AND LIFE
SCIENCES in BYDGOSZCZ

International
Seminar

**GAMBIT
2008**



Gdansk
University of Technology



International
Seminar

**GAMBIT
2008**

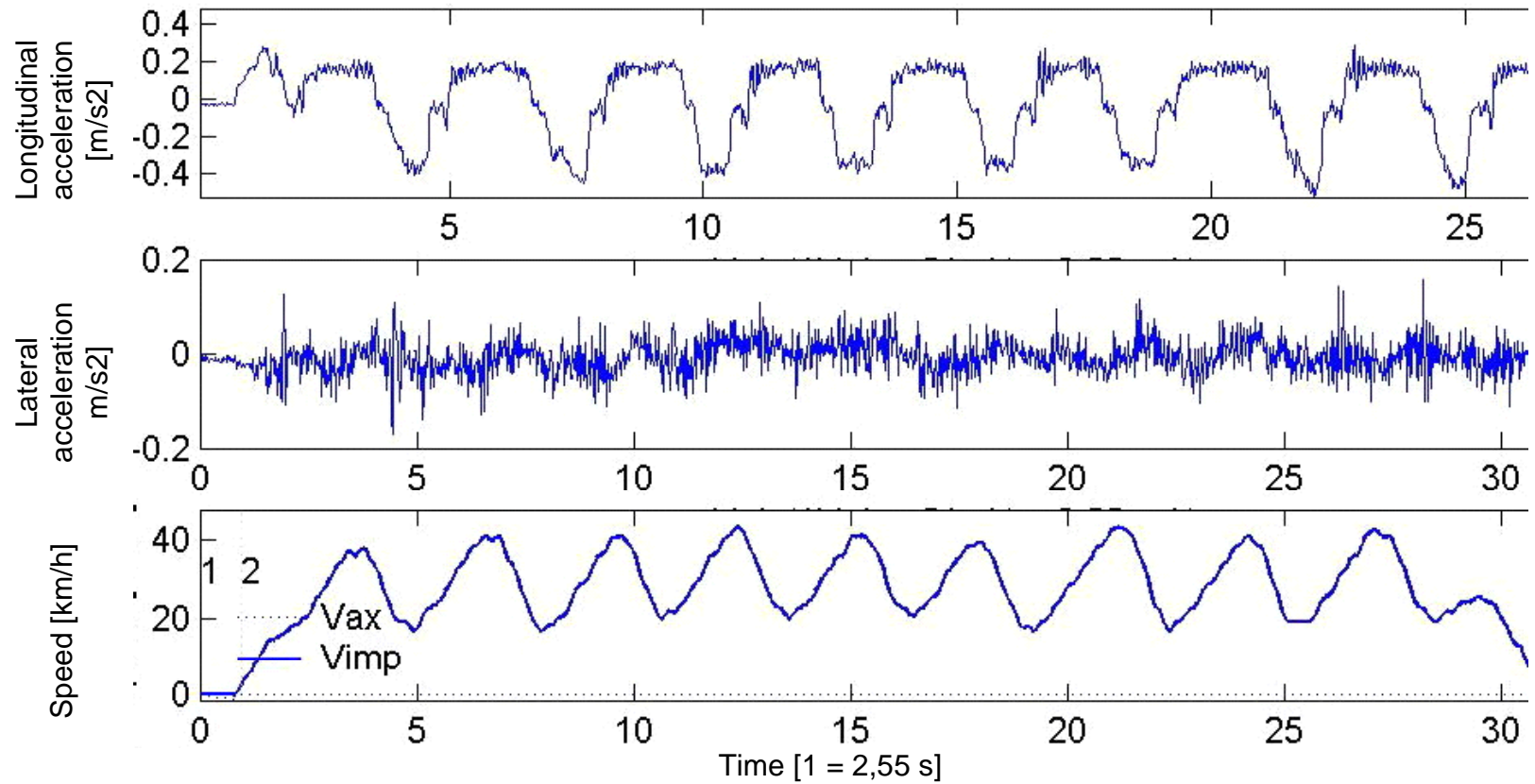

T. Szczuraszek J. Kempa
UNIVERSITY of TECHNOLOGY AND LIFE
SCIENCIES in BYDGOSZCZ



Gdansk
University of Technology



FOUNDATION
for CIVIL ENGINEERING DEVELOPMENT

International
Seminar

**GAMBIT
2008**

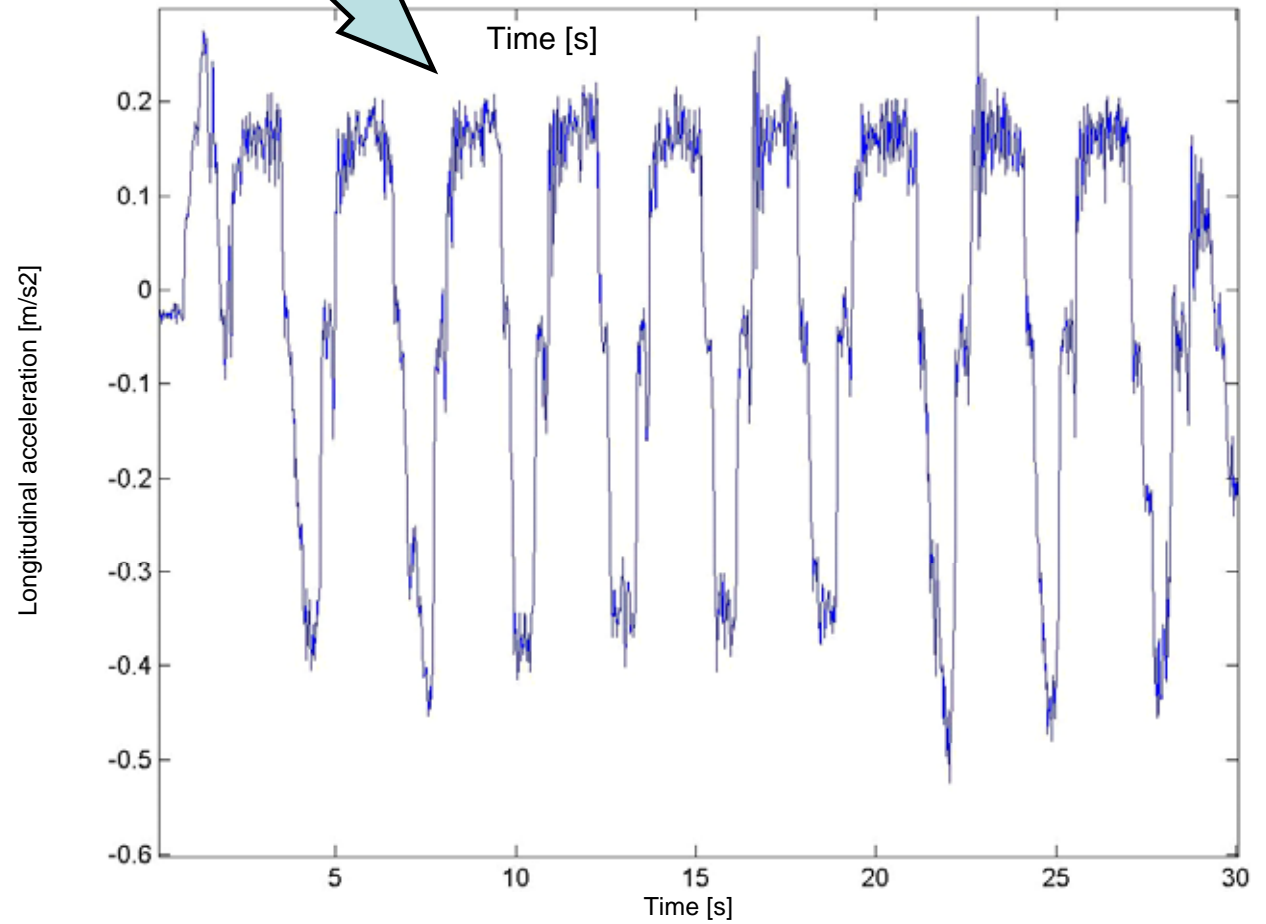
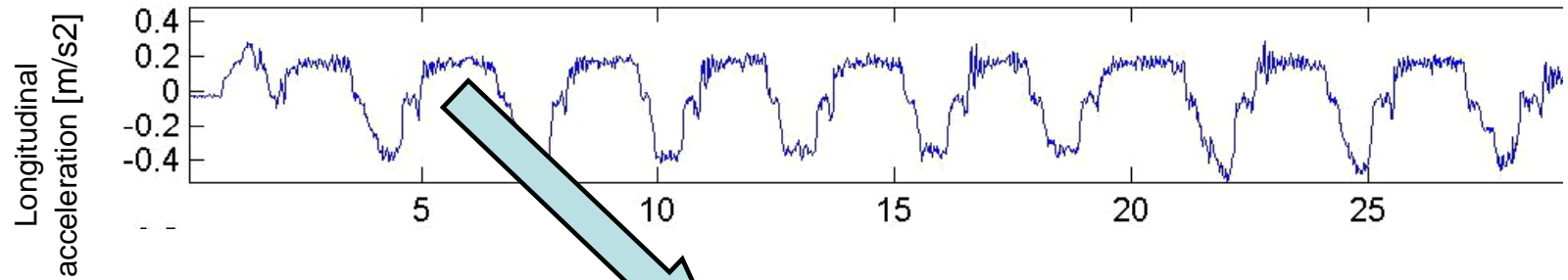

T. Szczuraszek J. Kempa
UNIVERSITY of TECHNOLOGY AND LIFE
SCIENCES in BYDGOSZCZ



Gdansk
University of Technology



FOUNDATION
for CIVIL ENGINEERING DEVELOPMENT

International
Seminar

**GAMBIT
2008**

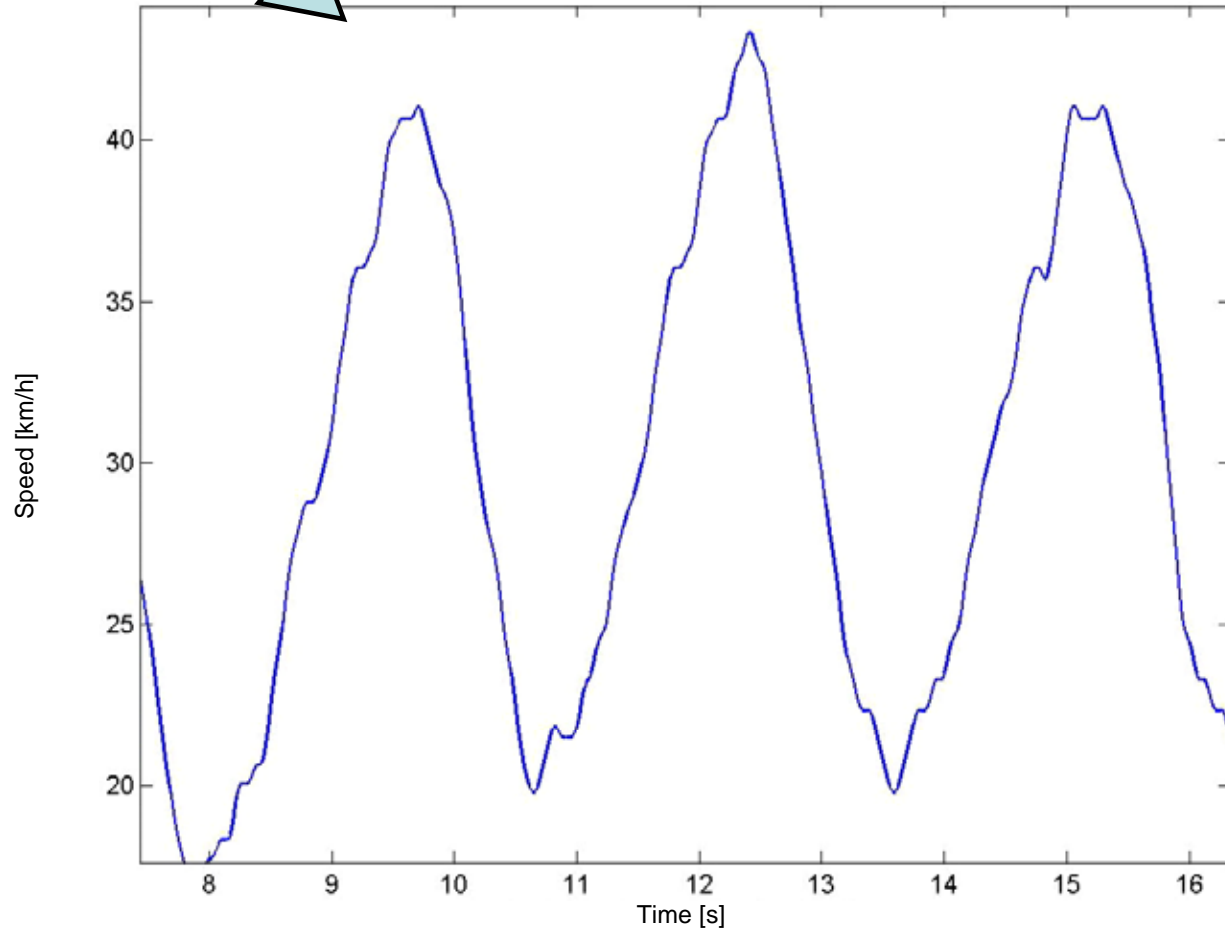
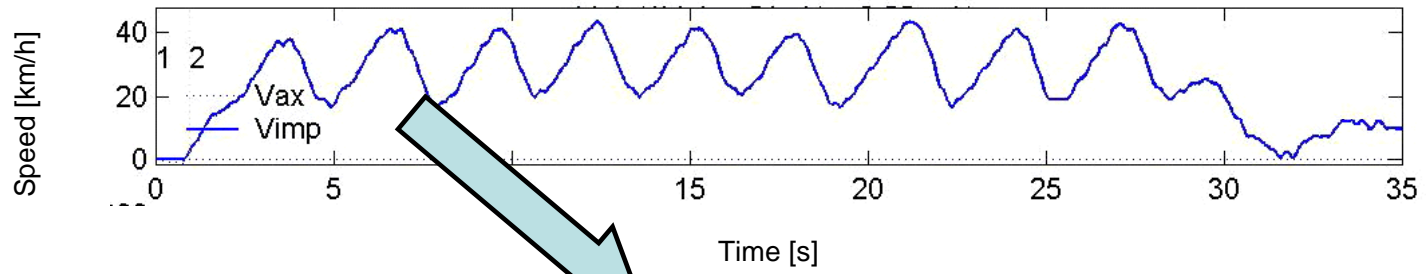

T. Szczuraszek J. Kempa
UNIVERSITY of TECHNOLOGY AND LIFE
SCIENCIES in BYDGOSZCZ



Gdansk
University of Technology



FOUNDATION
for CIVIL ENGINEERING DEVELOPMENT

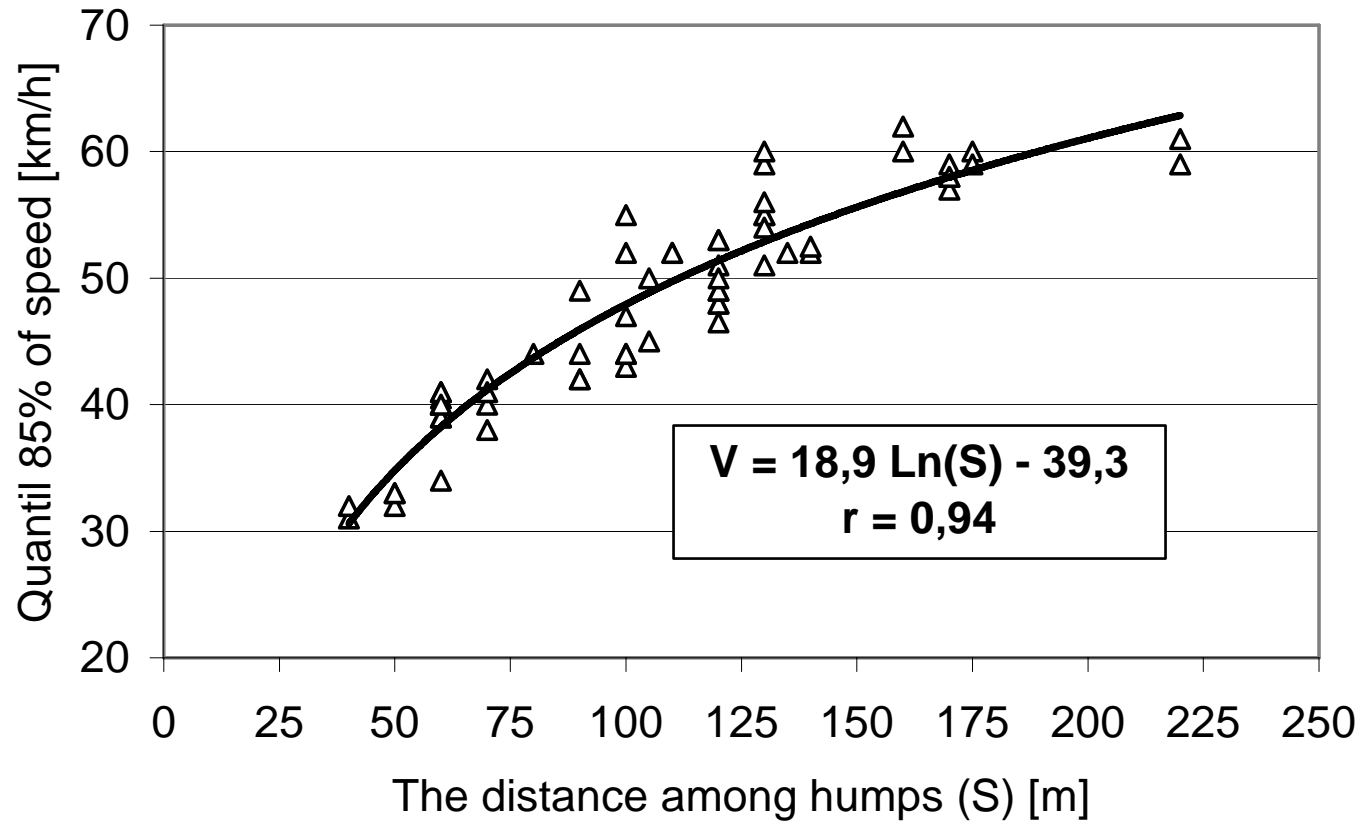

International
Seminar

GAMBIT
2008

T. Szczuraszek J. Kempa
UNIVERSITY of TECHNOLOGY AND LIFE
SCIENCES in BYDGOSZCZ



Gdansk
University of Technology



FOUNDATION
BY CIVIL ENGINEERING DEVELOPMENT

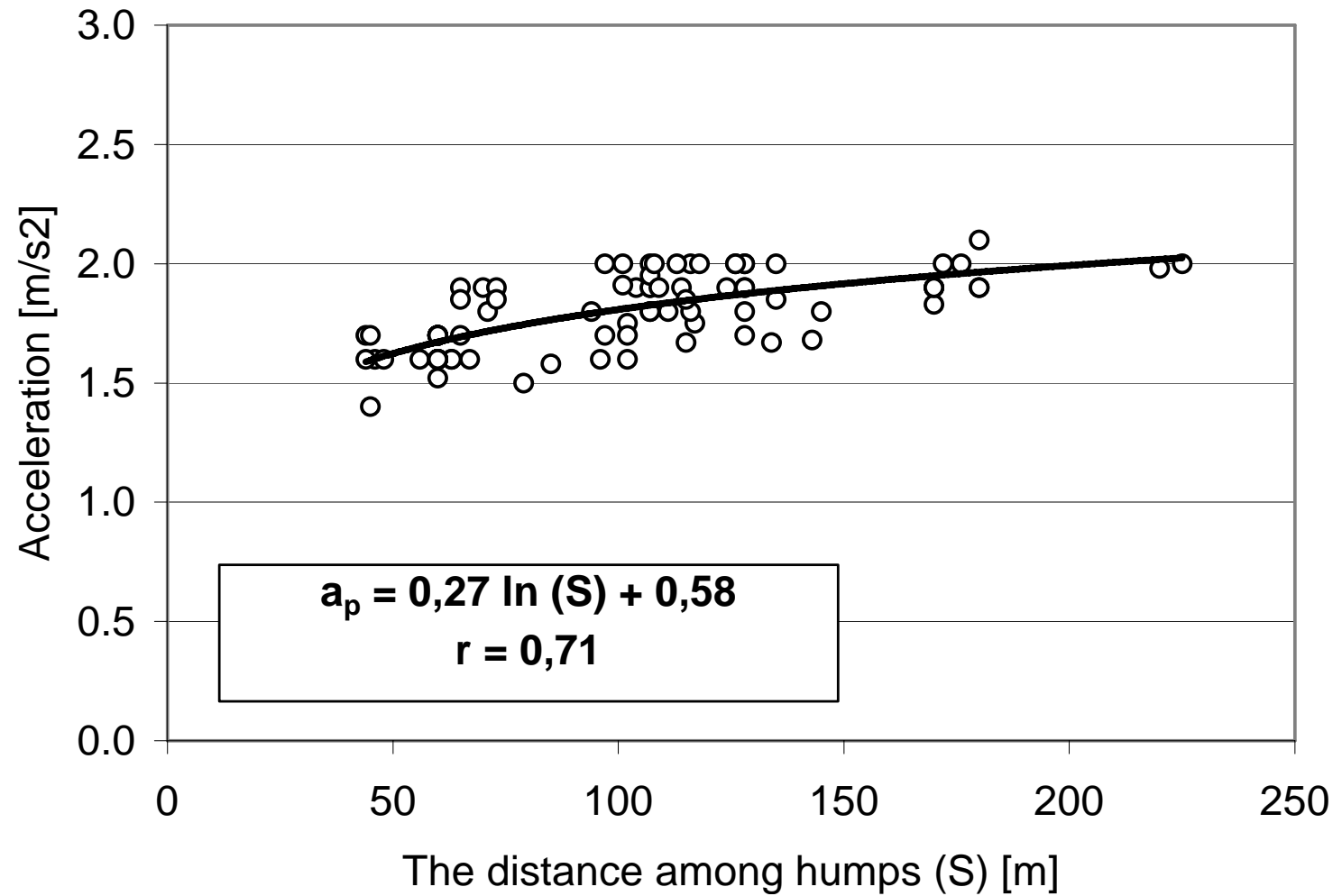

International
Seminar

GAMBIT
2008

T. Szczuraszek J. Kempa
UNIVERSITY of TECHNOLOGY AND LIFE
SCIENCES in BYDGOSZCZ



Gdansk
University of Technology



FOUNDATION
BY CIVIL ENGINEERING DEVELOPMENT

International
Seminar

GAMBIT
2008

The distance among humps (S) [m]

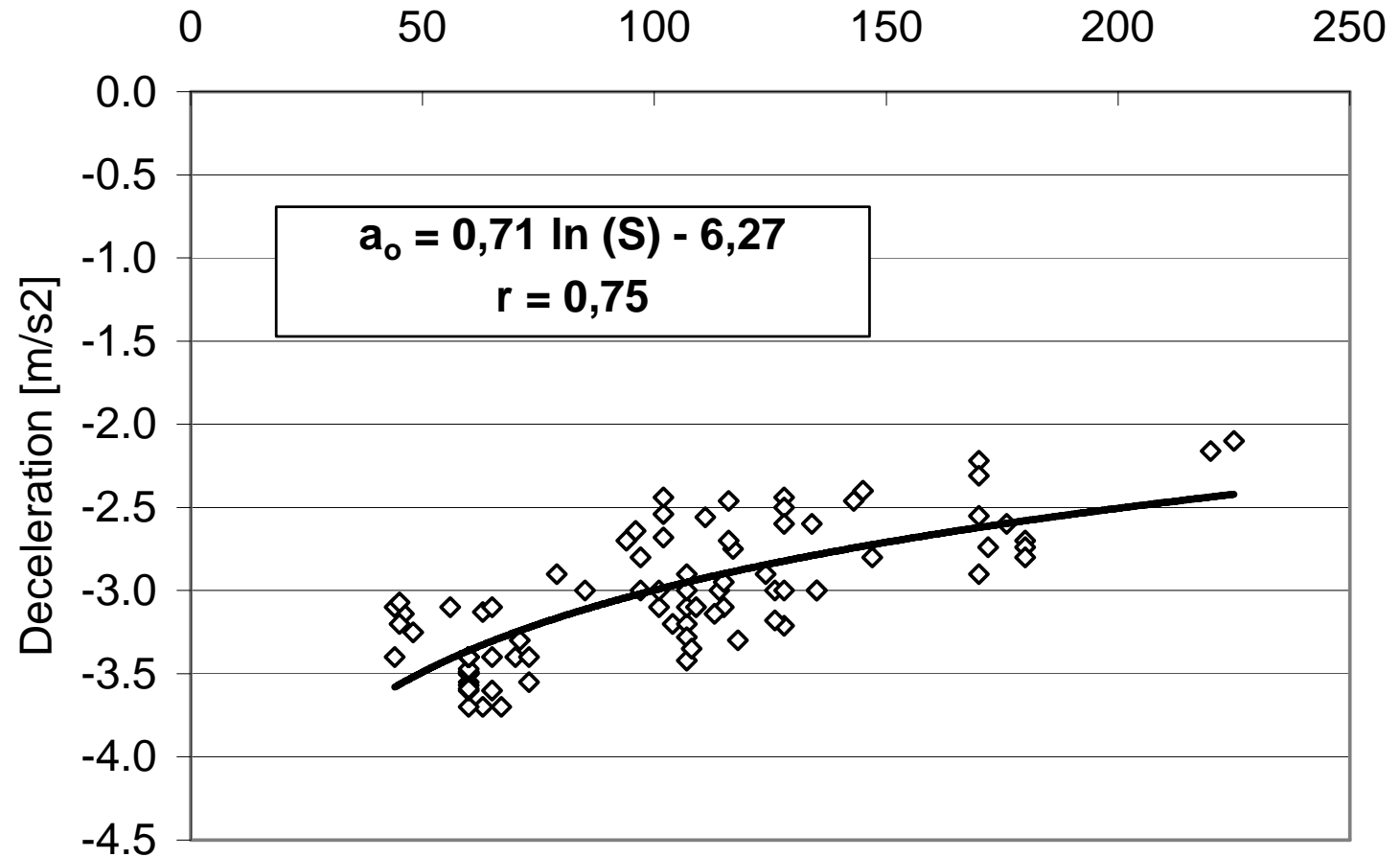

T. Szczuraszek J. Kempa
UNIVERSITY of TECHNOLOGY AND LIFE
SCIENCES in BYDGOSZCZ



Gdansk
University of Technology



FOUNDATION
for CIVIL ENGINEERING DEVELOPMENT

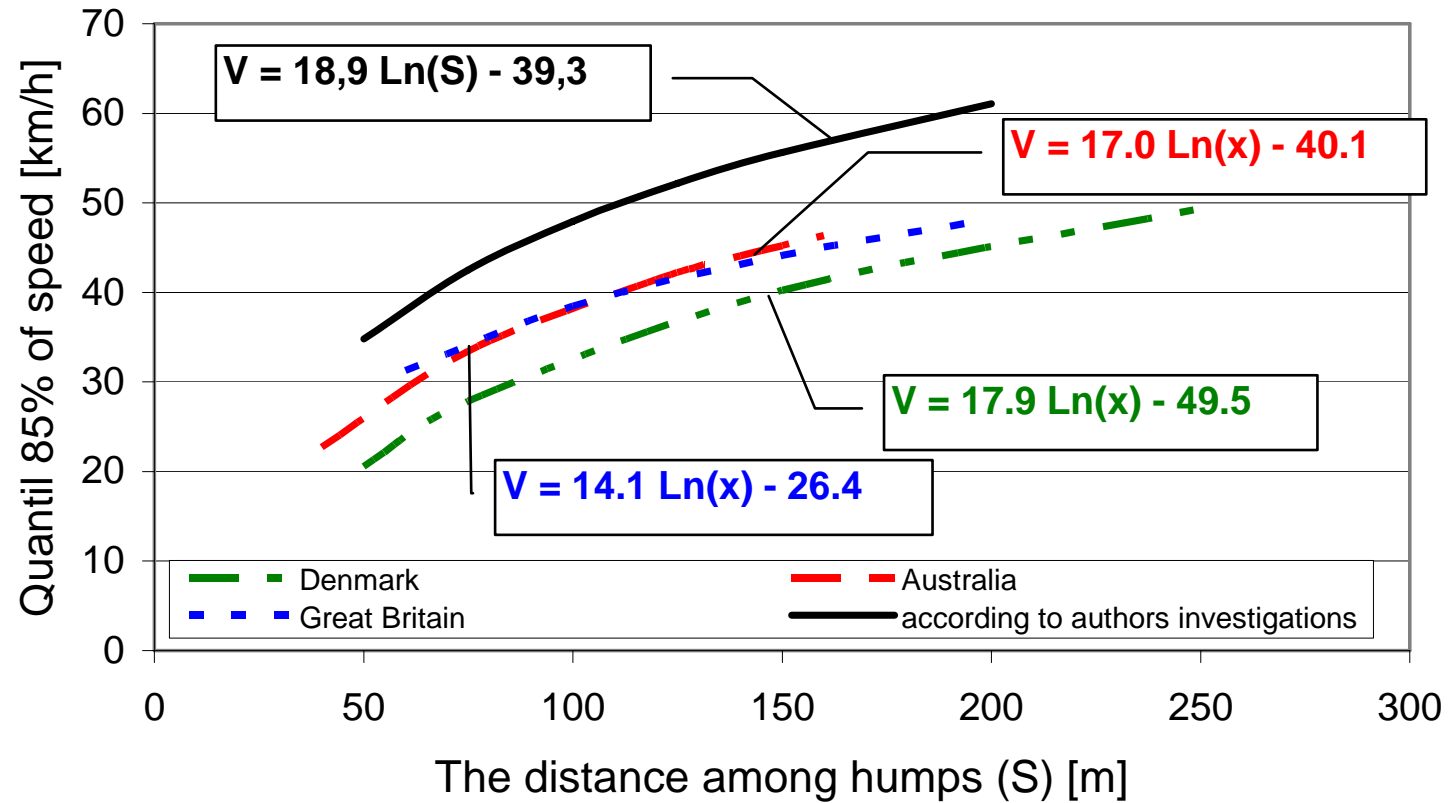

International
Seminar

**GAMBIT
2008**

T. Szczuraszek J. Kempa
UNIVERSITY of TECHNOLOGY AND LIFE
SCIENCES in BYDGOSZCZ